

Project	Quantity	Item #
Model Specified:		CSI Section 11400

## "D-Width" Hinged Glass Door Reach-In Refrigerators/Self-Contained



Model Shown One Section  
(shown with optional interior arrangements & casters)



Stainless Exterior  
& Interior



Stainless Exterior,  
Anodized Alumi-  
num Interior

### One & Two Section Models, 32" Deep

1-Section Full Length Door Model	RHT132DUT-FHG
2-Section Full Length Door Model	RHT232DUT-FHG
1-Section Half Length Door Model	RHT132DUT-HHG
2-Section Half Length Door Model	RHT232DUT-HHG

1-Section Full Length Door Model	AHT132DUT-FHG
2-Section Full Length Door Model	AHT232DUT-FHG
1-Section Half Length Door Model	AHT132DUT-HHG
2-Section Half Length Door Model	AHT232DUT-HHG

These "D-Width" reach-in refrigerator models are equipped with hinged glass doors in order to maximize product visibility. Each is supplied standard with such high quality features as balanced refrigeration systems, microprocessor controls, and stainless steel exteriors. Additionally, they offer the widest range of optional accessories to choose from, and can be specified for use with many different applications, including: Foodservice, Correctional, Institutional, Export, etc.

## Standard Product Features

- Traulsen's Smart Control With LED Display
- StayClear™ Condenser
- R-Series: Stainless Steel Exterior & Interior
- A-Series: Stainless Steel Exterior/Anodized Aluminum Interior
- Balanced, Self-Contained Refrigeration System Using R-450A
- Rear Biased Return Air Duct
- Full or Half Length Hinged Glass Doors With Locks
- Self-Closing Doors With Stay Open Feature At 120 Degrees
- Guaranteed For Life Cam-Lift Hinges
- Stainless Steel Vertical Door Handle(s)
- Standard Door Hinging: 132D = Right, 232D = Left/Right, (other hinging not available for two-section models)
- LED Lights With Exterior Switch
- Stainless Steel Breaker Caps
- Three Adjustable Wire Shelves Per Section, Supported On Shelf Pins (installed at the factory)
- Automatic Non-Electric Condensate Evaporator
- Magnetic Snap-In EZ-Clean Door Gasket(s)
- Thermostatic Expansion Valve Metering Device
- Stainless Steel One-Piece Louver Assembly
- 9' Cord & Plug Attached
- Set of Four (4) 6" High Adjustable Stainless Steel Legs
- Three Year Parts And Labor Warranty
- Five Year Compressor Warranty

## Options & Accessories

- Stainless Steel Finished Back With Rear Louvers
- No. 1 Type Tray Slides To Accommodate either (1) 18" x 26" or (2) 14" x 18" Pans
- Export 220/50/1 Voltage
- 208/115/60/1 Voltage In Lieu Of Standard 115/60/1
- Kool Klad Exterior Laminate Decor
- Set of Four (4) 6" High Casters In Lieu of Legs
- Set of Four (4) 4-5/8" High Casters In Lieu of Legs
- 4-1/2" High Stainless Steel Base In Lieu of Legs
- 6" High Stainless Steel Kickplate (for use with standard legs)
- Remote Applications (see spec sheet TR35837 for details)<sup>4</sup>



Listed by Underwriters Laboratories Inc., to U.S. and Canadian safety standards and Listed by NSF International.



Approval: \_\_\_\_\_



**TRAUlsen**  
4401 BLUE MOUND RD.  
PHONE 1 (800) 825-8220  
Website: www.traulsen.com

FT. WORTH, TX 76106  
FAX-MKTG. 1 (817) 624-4302

Project	Quantity	Item #
Model Specified:		CSI Section 11400

## Specifications

### Construction, Hardware and Insulation

Cabinet exterior front, one piece sides and lower assembly are constructed of 20 gauge stainless steel with #4 finish. Cabinet interior is constructed of stainless steel (anodized aluminum in the A-Series). The exterior cabinet top, back and bottom are constructed of heavy gauge galvanized steel. A set of four (4) adjustable 6" high stainless steel legs are included.

Doors are equipped with removable plug cylinder locks and guaranteed for life cam-lift, gravity action, self-closing metal, glide hinges with stay open feature at 120 degrees. An external switch is provided to activate the interior LED lighting.

Gasket profile and material simplify cleaning and increase overall gasket life. Anti-condensate heaters are located behind each door opening.

The cabinet is insulated with an average of 2" thick high density, non-CFC, foamed in place polyurethane.

DIMENSIONAL DATA	R/AHT132DUT	R/AHT232DUT
Net capacity cu. ft.	17.7 (501 cu l)	42.0 (1190 cu l)
Length - overall in.	24 (61.0 cm)	48 (121.9 cm)
Depth - overall in.	35 (88.8 cm)	35 (88.8 cm)
Depth - over body in.	32 (81.3 cm)	32 (81.3 cm)
Depth - door open 90° in.	54 <sup>3</sup> / <sub>4</sub> (139.1 cm)	54 <sup>3</sup> / <sub>4</sub> (139.1 cm)
Clear door width in.	18 <sup>5</sup> / <sub>8</sub> (47.3 cm)	19 <sup>9</sup> / <sub>16</sub> (54.6 cm)
Clear half-door height in.	27 <sup>1</sup> / <sub>2</sub> (69.9 cm)	27 <sup>1</sup> / <sub>2</sub> (69.9 cm)
Clear full-door height in.	57 <sup>5</sup> / <sub>8</sub> (146.3 cm)	57 <sup>5</sup> / <sub>8</sub> (146.3 cm)
Height - overall on 6" legs <sup>3</sup>	83 <sup>1</sup> / <sub>4</sub> (211.5 cm)	83 <sup>1</sup> / <sub>4</sub> (211.5 cm)
No. Standard Shelves	3	6
Shelf area sq. ft. <sup>1</sup>	14.2 (1.3 sq m)	31.6 (2.9 sq m)
RHT Net Wt. lbs.	330 (150 kg)	574 (260 kg)
AHT Net Wt. lbs.	290 (132 kg)	446 (202 kg)
ELECTRICAL DATA		
Voltage	115/60/1	115/60/1
Feed wires with Ground	3	3
Full load amperes <sup>2</sup>	8.0	10.3
REFRIGERATION DATA		
Refrigerant	R-450A	R-450A
Refrigerant Charge Amount oz	10	27
BTU/HR H.P. <sup>4</sup>	1710 (½ HP)	4200 (½ HP)

### Refrigeration System

A top mounted, self-contained, balanced refrigeration system using environmentally friendly, non-flammable R-450A refrigerant is conveniently located behind the one piece lower assembly. It features a finless StayClear™ condenser, thermostatic expansion valve, air-cooled hermetic compressor, plenum effect blower coil, large, high humidity evaporator coil located outside the food zone and a top mounted non-electric condensate evaporator. Biased return air duct protects against introduction of warm kitchen air, promoting even temperature maintenance and efficient operation. A 9' cord and plug is provided. Standard operating temperature is 34 to 38°F.

### Controller

Traulsen's Smart Control features advanced control algorithms and sophisticated diagnostic capabilities. Smart sensors will adapt the operation of the refrigeration system to a variety of environments and usage patterns. The Smart Control offers a complete set of visual alarms designed to alert the user to critical events. In the event of an alarm, a dedicated Alarm LED will illuminate, informing the user of the critical event and describing the event in the large, easy to read full text display.

### Interior

Standard interior arrangements include three (3) coated wire shelves per section, mounted on shelf pins. Shelves are full-width, and do not have any large gaps between them requiring the use of "bridge" or "junior shelves". Recommended load limit per shelf should not exceed 225 lbs. Optional tray slides may be purchased in combination with, or in lieu of these. Interior arrangements are installed at the factory.

### Warranties

Both a three year parts and labor warranty and a five year compressor warranty (self-contained models only) are provided standard.

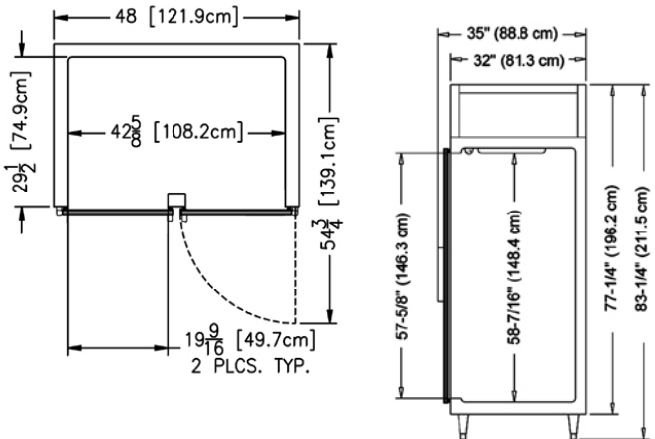
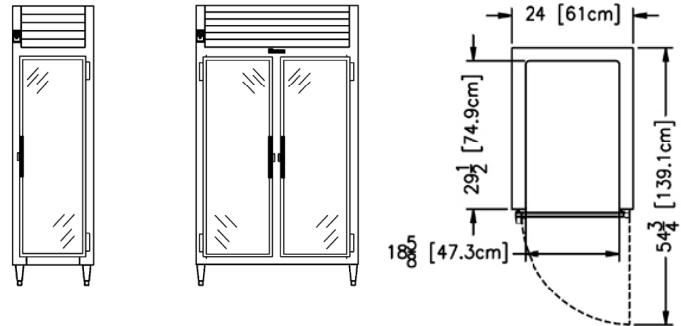

### NOTES

NOTE: Figures in parentheses reflect metric equivalents.

1= Area of standard shelf compliment only, does not include storage area of additional shelves or available on cabinet bottom.

2= Amp figure shown as supplied with standard LED lighting.

3= Based on a 90° F ambient and 20° F evaporator.

4= For approximate remote weights deduct 40 lbs. from respective net or gross weight. For other information on remote models, please refer to spec sheet TR35832.

5= 12" Top clearance preferred for optimum performance and service access.



1 Section Models Equipped  
With One NEMA 5-15P Plug



2 Section Models Equipped  
With One NEMA 5-20P Plug

NOTE: Full load amps and plug style may vary depending on electrical options chosen and condensing unit employed.

NOTE: When ordering please specify: Voltage, Hinging, Door Size, Options and any additional warranties.

Continued product development may necessitate specification changes without notice.

Part No. TR35832 (REV. 05-14-21)

TRAUlsen  
4401 BLUE MOUND RD.  
PHONE 1 (800) 825-8220  
Website: www.traulsen.com

FT. WORTH, TX 76106  
FAX-MKTG. 1 (817) 624-4302

**Traulsen**