



Project \_\_\_\_\_  
 AIA # \_\_\_\_\_ SIS # \_\_\_\_\_  
 Item # \_\_\_\_\_ Quantity \_\_\_\_\_ C.S.I. Section 114000



DEALERS CHOICE G-SERIES

## G-SERIES

### 1-Section Refrigerator Reach-In Self-Contained Hinged Glass Door(s)



(shown with solid doors)

### STANDARD PRODUCT FEATURES

- High Performance, Energy Efficient Refrigeration System
- Reliable Microprocessor Control With LED Temperature Display
- Evaporator Coil Outside Food Zone Provides More Usable Space
- Load-Sure Guard Prevents Problems From Improper Loading
- Stainless Steel Front & Louver Panel, Triple Pane Glass Door, Anodized Aluminum Sides & Interior
- Full Height Length Hinged Glass Doors With Locks
- Long Life EZ-Clean Door Gaskets
- Three (3) Epoxy Coated Shelves Per Section (factory installed)
- Easy to Maintain Front Facing Condenser Coil
- 6" High Locking Casters
- Guaranteed for Life Door Hinges
- 3-Year Parts & Labor Warranty
- 2-Years Additional Compressor Parts Warranty



Many models are ENERGY STAR® listed. Please refer to [www.energystar.gov](http://www.energystar.gov) to view the most up-to-date product listing and performance data.



**Intertek**  
4004142  
Conforms to UL STD. 471  
Cert. to CAN/CSA STD. C22.2 NO.120

This unit is listed to the applicable UL, CSA and NSF Standards by an approved NRTL. Consult the factory or unit's data plate for approval information.

### ACCESSORIES & OPTIONS (\*field installed)

- Tray Slides for 18" x 26" Sheet Pans\*
- Tray Slides for 12" x 20" Food Pans\*
- Tray Slides for 14" x 18" Sheet Pans\*
- Additional Shelves\*
- 6" High Legs\*

\*Please refer to form number TR35872 for precise kit details. See back page for tray slide versatility chart.

### AVAILABLE CONFIGURATIONS

#### Half-Height Door Models

G11000  
G11001

#### Hinging

Right  
Left

#### Full-Height Door Models

G11010  
G11011

#### Hinging

Right  
Left

Approved by \_\_\_\_\_ Date \_\_\_\_\_ Approved by \_\_\_\_\_ Date \_\_\_\_\_



## MODELS

Half Height Door Models: G11000, G11001

CLICK  
**TRANSFER**  
For KCL CADalog Website

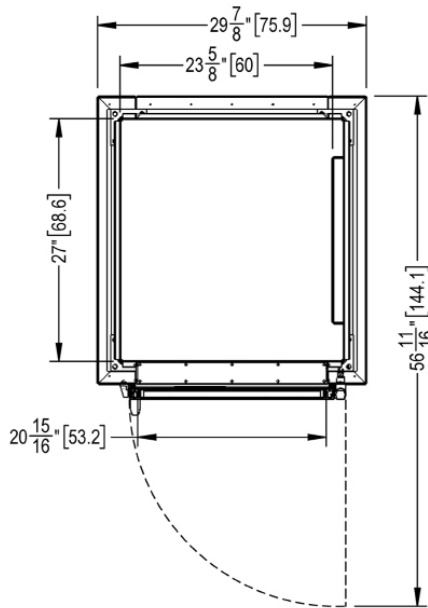
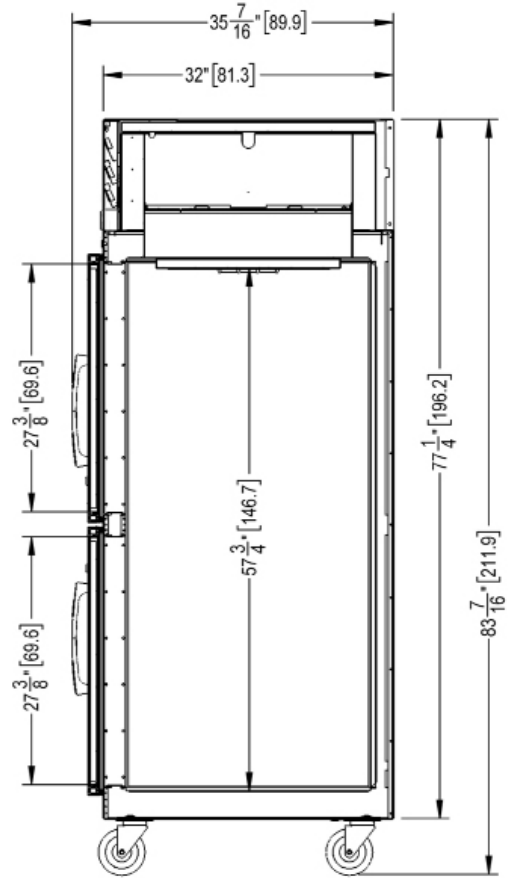
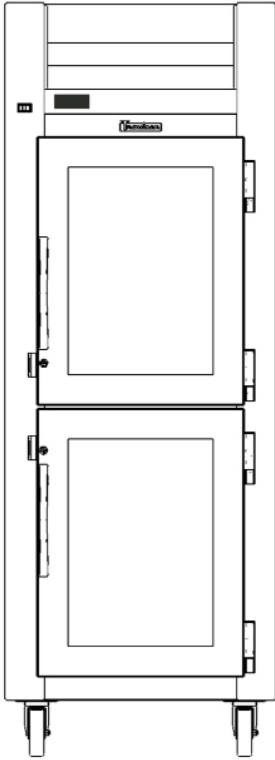

# G-SERIES

1-Section refrigerator Reach-In  
Self-Contained Hinged Glass Door(s)

## MODELS

Full Height Door Models: G11010, G11011

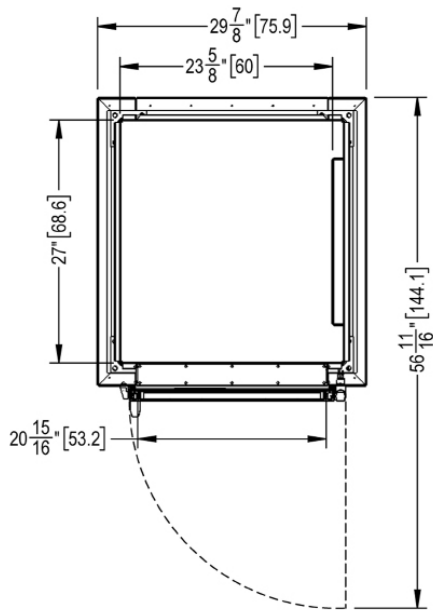
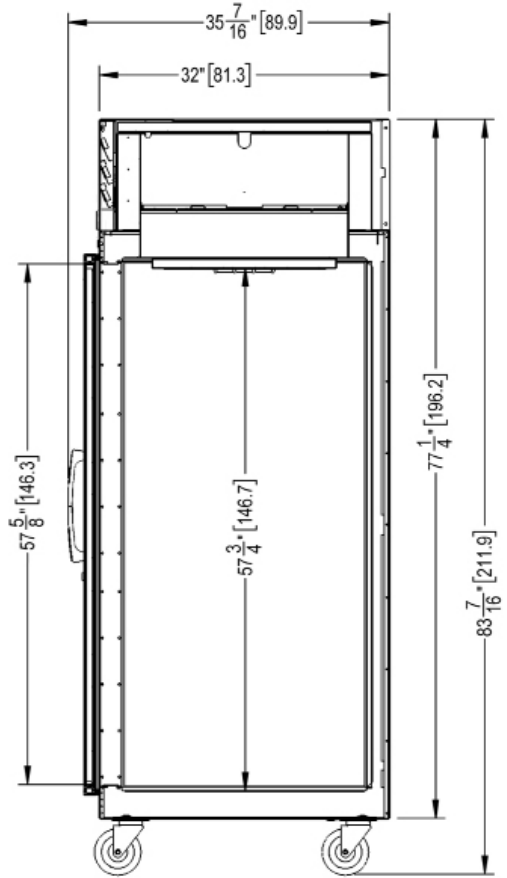
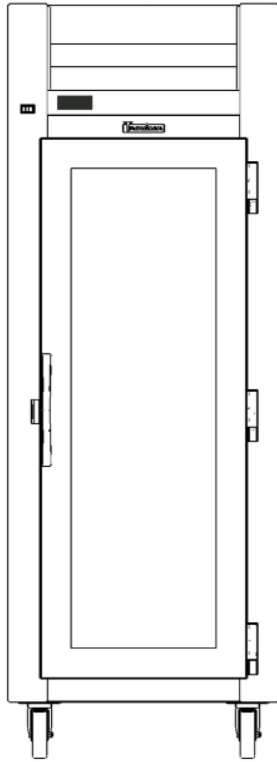



# G-SERIES

## 1-Section Refrigerator Reach-In Self-Contained Hinged Glass Door(s)

### MODELS

Half Height Door Models: G11000, G11001

Full Height Door Models: G11010, G11011

MODELS	G110__
<b>DIMENSIONAL DATA</b>	
Net Capacity cu. ft. <sup>1</sup>	23.67 (670 l)   23.57 (667 l)
L x D x H - Overall in. <sup>2</sup>	29 <sup>7</sup> / <sub>8</sub> (75.9 cm) x 35 (88.8 cm) x 83 <sup>7</sup> / <sub>8</sub> (211.9 cm)
Depth - over body in.	32 (81.3 cm)
Depth - door open 90° in.	56 <sup>7</sup> / <sub>8</sub> (144.5 cm)
Clear half-door W x H in.	21 <sup>1</sup> / <sub>8</sub> (53.6 cm) x 27 <sup>1</sup> / <sub>2</sub> (69.9 cm)
Clear full-door W x H in.	21 <sup>1</sup> / <sub>8</sub> (53.6 cm) x 57 <sup>5</sup> / <sub>8</sub> (146.3 cm)
No. Standard Shelves	3
Shelf Area sq. ft. <sup>3</sup>	18.8 (1.75 sq m)
<b>ELECTRICAL DATA</b>	
Voltage   Plug	115/60/1   NEMA 5-15P (attached)
Feed wires with ground	3
Full Load Amperes   MDEC <sup>4</sup>	7.4   3.06 kWh/Day
<b>REFRIGERATION DATA</b>	
Refrigerant	R-450A
Refrigerant Charge Amount	16 oz (453.6 g)
BTU/HR   H.P. <sup>5</sup>	2240   1/3 HP
Required Clearance	12" Above
<b>SHIPPING DATA</b>	
L x D x H Crated in.	48 (122 cm) x 42 (107 cm) x 85(216 cm)
Volume Crated cu. ft.	99 (2803 l)
Uncrated   Crated Weight lbs.	305 (138 kg)   350 (159 kg)

#### NOTES:

1. Net Capacity cu. ft. = Half Height Door | Full Height Door models.
2. Height shown when mounted on standard 6" high casters.
3. Figure shown reflects the area of standard shelf compliment.
4. MDEC = Maximum Daily Energy Consumption
5. Based on a 90°F ambient and 20°F evaporator.

### EQUIPMENT SPECIFICATIONS

#### CONSTRUCTION, HARDWARE, INSULATION

Cabinet exterior front and louver assembly are constructed of heavy gauge stainless steel. Cabinet sides (including returns) and interior are constructed of anodized aluminum. The exterior cabinet top, back and bottom are constructed of heavy gauge galvanized steel. A set of four (4) 6" high casters are included.

Doors are equipped with removable plug cylinder locks and guaranteed for life cam-lift, gravity action, self-closing metal, glide hinges with stay open feature at 120 degrees. An exterior mounted switch is provided to operate the interior LED lighting. Each door includes a vertically mounted stainless steel handle.

Gasket profile and durable long life material simplify cleaning and increase overall gasket life. Anti-condensate heaters are located behind each door opening. The cabinet is insulated with an average of 2" thick high density, non-CFC, foamed in place polyurethane.

#### SELF-CONTAINED REFRIGERATION SYSTEM

A top mounted, self-contained, balanced refrigeration system using environmentally friendly, non-flammable R-450A refrigerant is conveniently located behind the one piece louver assembly. It features an easy to clean front facing condenser, thermostatic expansion valve, air-cooled hermetic compressor, large, high humidity evaporator coil located outside the food zone and a top mounted non-electric condensate evaporator. A 9' cord and plug is provided. Standard operating temperature is 34 to 38°F.

#### CONTROL

The easy to use water resistant microprocessor control system is supplied standard. It includes a 3-Digit LED Display, and a Fahrenheit or Celsius Temperature Scale Display Capability.

#### INTERIOR ARRANGEMENTS

Standard interior arrangements include three (3) epoxy coated steel wire shelves, mounted on shelf pins, installed at the factory. Recommended load limit per shelf should not exceed 225 lbs.

#### DOMESTIC WARRANTY

Both a three year parts and labor warranty and an additional two year compressor parts warranty (for a total of five on self-contained models) are provided standard.

### OPTIONAL ACCESSORY TRAY SLIDE VERSATILITY CHART

TRAY SLIDE DRAWINGS						
TRAY SLIDE OFFERING	#1 (1) 18" x26" or (2) 14"x18"	#4 (Rod Type) (1) 18" x26"	Universal (1) 18" x26" or (2) 14"x18" or (2) 12"x20"	#1 EZ-Change (1) 18" x26" or (2) 14"x18"	Universal EZ-Change (1) 18" x26" or (2) 14"x18" or (2) 12"x20"	HD Universal EZ-Change (1) 18" x26" or (2) 14"x18" or (2) 12"x20"
SPACING CAPACITY DOOR SIZE	2" 28 Pairs Full Door & 13 Half 3" 19 Pairs Full Door & 09 Half 4" 14 Pairs Full Door & 07 Half 5" 11 Pairs Full Door & 05 Half	1 1/2" 38 Pairs Full Door (2 Pair) 1 1/2" 18 Pairs Half Door (1 Pair)	4" 14 Pairs Full Door & 06 Half <sup>1</sup> 4" 14 Pairs Full Door & 07 Half <sup>2</sup> 5" 11 Pairs Full Door & 05 Half 6" 09 Pairs Full Door & 04 Half	2" 26 Pairs Full Door & 12 Half 4" 13 Pairs Full Door & 06 Half	2 1/4" 22 Pairs Full Door & 11 Half 4 1/2" 11 Pairs Full Door & 05 Half	4 1/2" 11 Pairs Full Door & 05 Half 9" 05 Pairs Full Door & 02 Half

- Upper Half Height Door<sup>1</sup>
- Lower Half Height Door<sup>2</sup>

CONTINUED PRODUCT DEVELOPMENT MAY NECESSITATE SPECIFICATION CHANGES WITHOUT NOTICE.